

Part NO. Detailed List

ITEM	P/N	LOGO	COLOUR
1	TUC13-32111601-01	With	Black
2	TUC13-32211601-02	With	White
3	TUC13-32111601-03	With Out	Black
4	TUC13-32211601-04	With Out	White

REV.	ECN NO OR DESCRIPTION	REVISED	DATE
A	PROPOSE ONLY	ERIC	2017.03.12

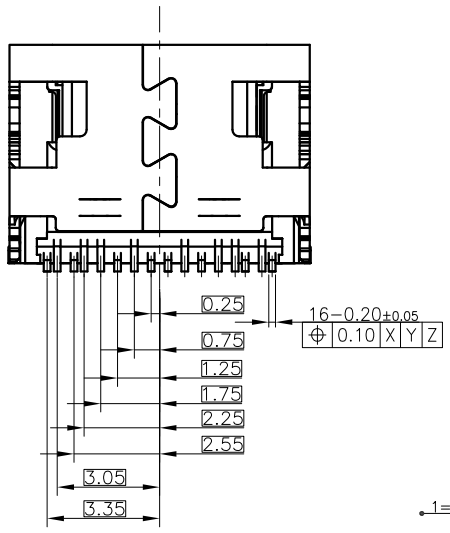
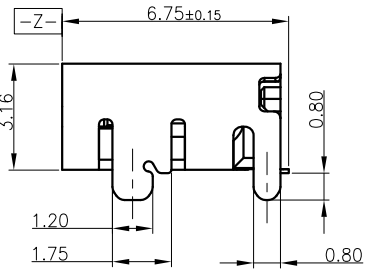
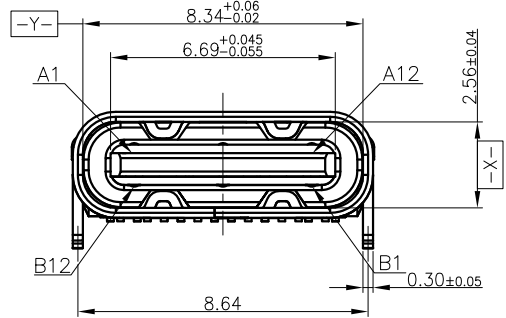
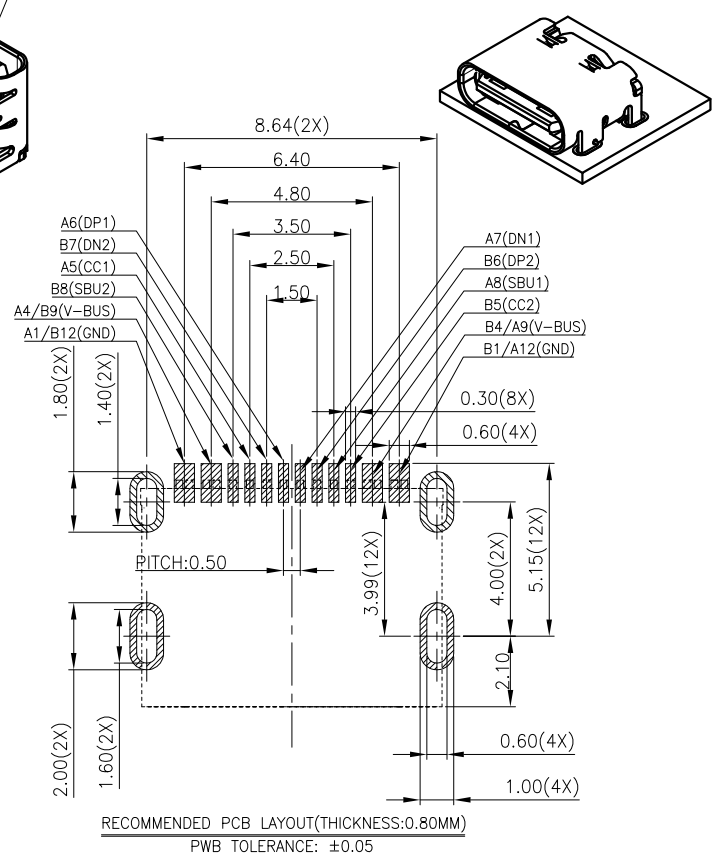
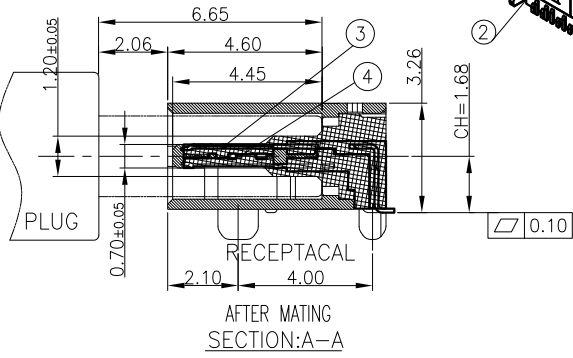
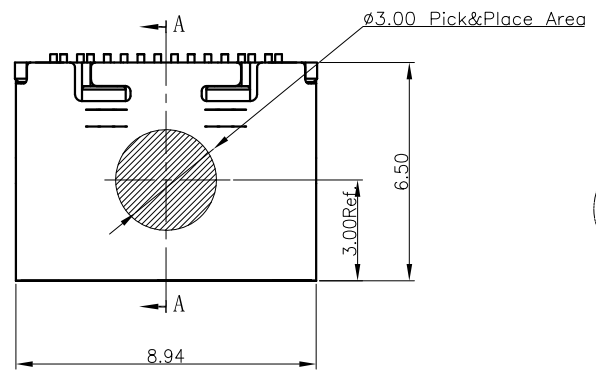

**SPECIFICATION:**

1.ELECTRICAL CHARACTERISTICS:

1.1 CURRENT RATING: 1.5A/Pin MAX(A4,A9,B4,B9)  
1.25A/Pin MAX(A1,A12,B1,B12),0.25A(OHER PIN)

1.2 CONTACT RESISTANCE: 40 MILLIONHM MAX.

1.3 DIELECTRIC WITHSTANDING VOLTAGE: 100 VAC r.m.s

1.4 INSULATION RESISTNACE: 100 MEGOHMS MIN.

2.MECHANICAL CHARACTERISTICS

2.1 INSERTION FORCE: 5~20N

2.2 EXTRACTION FORCE: Initial:8~20N;Durability:6~20N(1000cycles);

2.3 DURABILITY:10,000CYCLES

3.ENVIRONMENTAL CHARACTERISTICS

3.1 TEMPERATURE RANGE: -40 °C ~ 85 °C

3.2. IR REFLOW:

THE PEAK TEMPERATURE ON THE BOARD SHALL BE MAINTAINED FOR 10 SECONDS AT 260°C.

4.PART NO.:  
**TUC13-32 X 1 16 01-XX**

Product Order  
32:HEIGHT ON BOARD 3.2mm  
1=BLACK HOUSING/2=WHITE HOUSING  
1=WITH DULL POST

XX= Servies NO. SEE Detailed List  
01=1u" Au Plating On Contact Aero  
Pin NO. 16=16Pin

NO.	DESCRIPTION	QTY.	MATERIAL	FINISH
5	MID PLATE	1 PCS	STAINLESS STEEL	NO SURFACE TREATMENT
4	CONTACT B	1 SET	COPPER ALLOY	Ni 50u" MIN. UNDER PLATED OVER ALL. Au PLATED ON THE FUNCTIONAL AREA OF CONTACT. (GOLD PLATING THICKNESS FOLLOW THE P/N) PLATING SPECIFICATIONS OF THE SOLDER AREA FOLLOW THE P/N
3	CONTACT A	1 SET	COPPER ALLOY	
2	HOUSING	3 PCS	NYLON 46	COLOR: SEE TABLE
1	SHELL	1 PCS	STAINLESS STEEL	Ni 30u" MIN. UNDER PLATED OVER ALL.

UNLESS OTHERWISE SPECIFIED TOLERANCES		TACLEX ELECTRONICS CO., LTD.			
DECIMALS:	ANGLES:	TITLE	Type.C 16PIN L=6.5MM CONN. RECPTACLE		
X :±0.5	X :±2°	DWN	Johnie	PART NO. TCR13-32X11601-XX	
X.X :±0.30	X.X :±1°	CHKD	Kevin.d	SCALE:1:1	UNIT: mm
X.XX :±0.20		APVD	Simon.Mo	SIZE: A4	SHEET:1OF1
X.XXX :±0.10		DRAW NO.	C-DWG-TC13-01		CUSTOMER COPY