

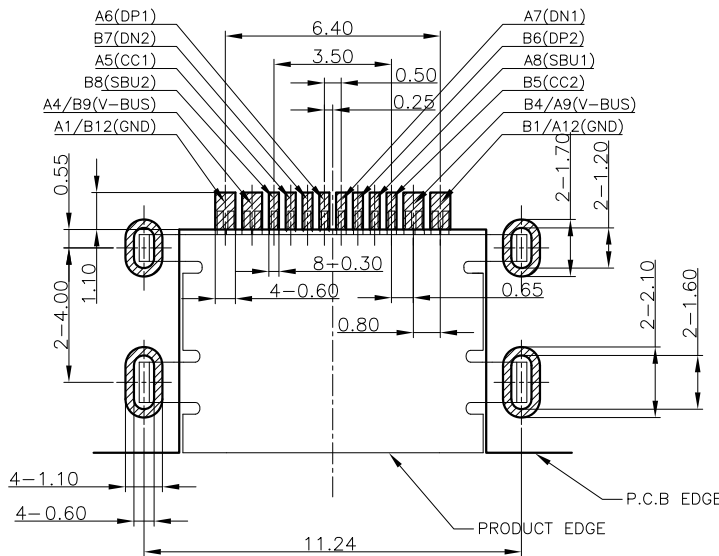

Part NO. Detailed List

ITEM	P/N	LOGO	WELDING
1	TCR16-22121602-01	With Out	With Out
2	TCR16-22121602-02	With	With Out
3	TCR16-22121602-03	With	With
4	TCR16-22121602-04	With Out	With

REV.	ECN NO OR DESCRIPTION	REVISED	DATE
A	PROPOSE ONLY	ERIC	2018.08.08

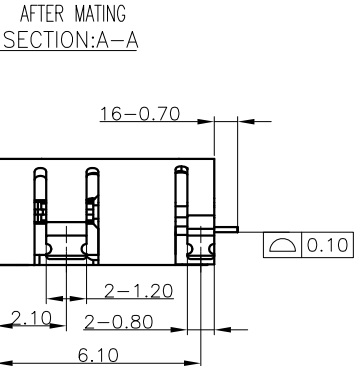
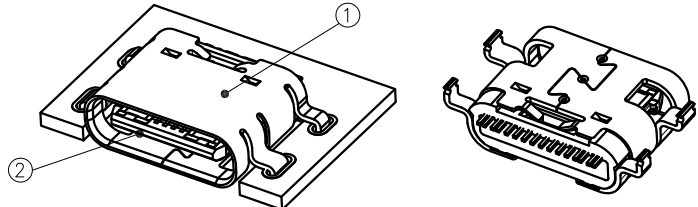
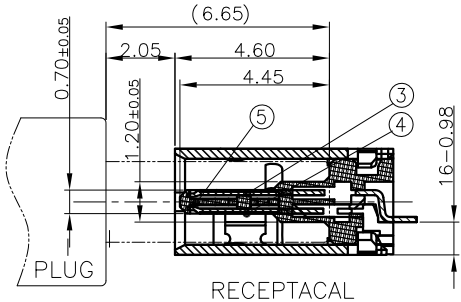
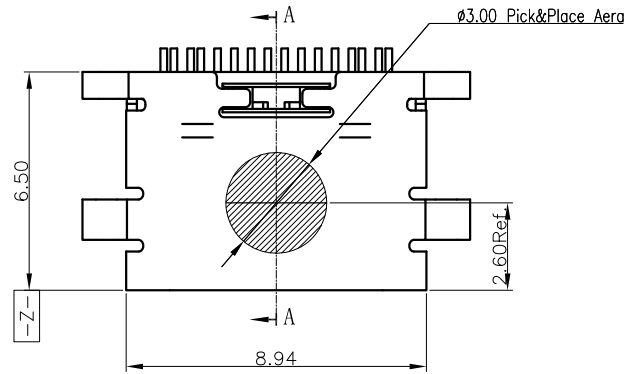

RECOMMENDED PCB LAYOUT(THICKNESS:0.80MM)
PWB TOLERANCE: ±0.05

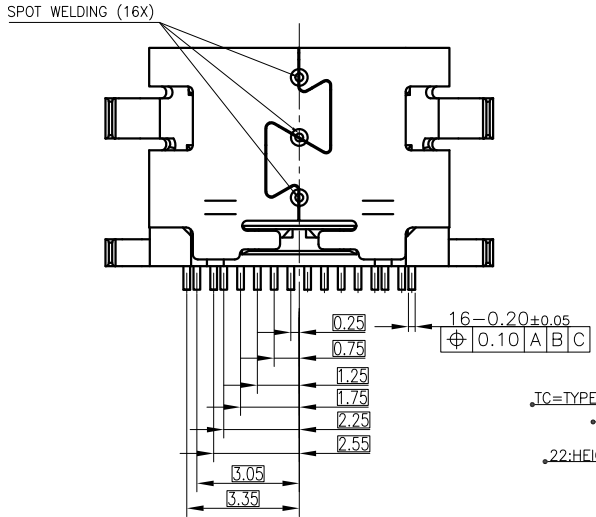
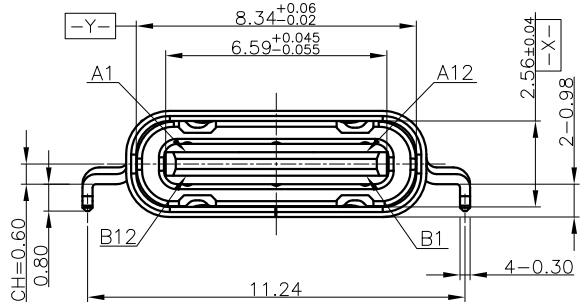

SPECIFICATION:

1.ELECTRICAL CHARACTERISTICS:

1.1 CURRENT RATING: 1.5A/Pin MAX(A4,A9,B4,B9)
1.25A/Pin MAX(A1,A12,B1,B12),0.25A(OHER PIN)

1.2 CONTACT RESISTANCE: 40 MILLIONHM MAX.

1.3 DIELECTRIC WITHSTANDING VOLTAGE: 100 VAC r.m.s

1.4 INSULATION RESISTNACE: 100 MEGOHMS MIN.

2.MECHANICAL CHARACTERISTICS

2.1 INSERTION FORCE: 5~20N

2.2 EXTRACTION FORCE: Initial:8~20N;Durability:6~20N(1000cycles);

2.3 DURABILITY:10,000CYCLES

3.ENVIRONMENTAL CHARACTERISTICS

3.1 TEMPERATURE RANGE: -40 °C ~ 85 °C

3.2. IR REFLOW:

THE PEAK TEMPERATURE ON THE BOARD SHALL BE MAINTAINED FOR 10 SECONDS AT 260°C.

4.PART NO.:

TCR16-22121602-XX

⑤	MID PLATE	1 PCS	STAINLESS STEEL	NO SURFACE TREATMENT
④	CONTACT B	1 SET	COPPER ALLOY	Ni 50u" MIN. UNDER PLATED OVER ALL. Au PLATED ON THE FUNCTIONAL AREA OF CONTACT. (GOLD PLATING THICKNESS FOLLOW THE P/N) PLATING SPECIFICATIONS OF THE SOLDER AREA FOLLOW THE P/N
③	CONTACT A	1 SET	COPPER ALLOY	
②	HOUSING	3 PCS	NYLON 46	COLOR: BLACK
①	SHELL	1 PCS	STAINLESS STEEL	Ni 30u" MIN. UNDER PLATED OVER ALL.

NO.	DESCRIPTION	QTY.	MATERIAL	FINISH
-----	-------------	------	----------	--------

UNLESS OTHERWISE SPECIFIED TOLERANCES

泰立電子有限公司
TACLEX ELECTRONICS CO., LTD

DECIMALS:	ANGLES:	TITLE	Type.C 16PIN L=6.5 CONN. RECPTACLE		
X :±0.5	X :±2°	DWN	chenjun	PART NO. TCR16-22121602-XX	
X.X :±0.30	X.X :±1°	CHKD	chenjun	SCALE:1:1	UNIT: mm
X.XX :±0.20		APVD	Kevin.d	SIZE: A4	SHEET:1OF1
X.XXX :±0.10		DRAW NO.	C-DWG-TCR16-02	SHEET:1OF1	REV: A
				CUSTOMER COPY	



REV.	ECN NO OR DESCRIPTION	REVISED	DATE
A	PROPOSE ONLY	ERIC	2018.08.08

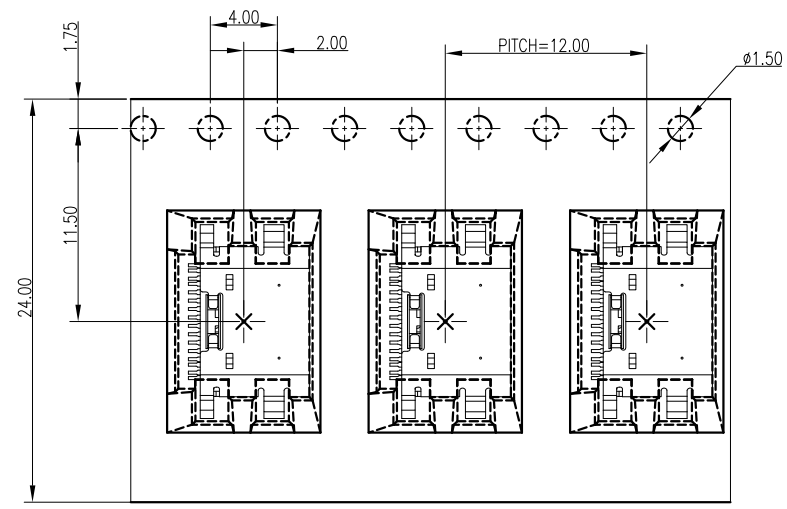
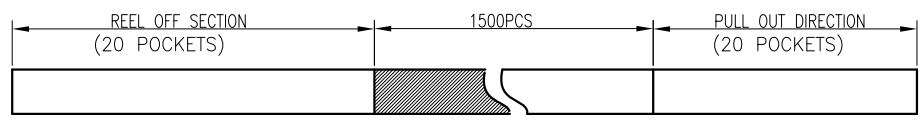

← PRODUCT PACKAGING DIRECTION
 CUSTOMER TO USE DIRECTION →

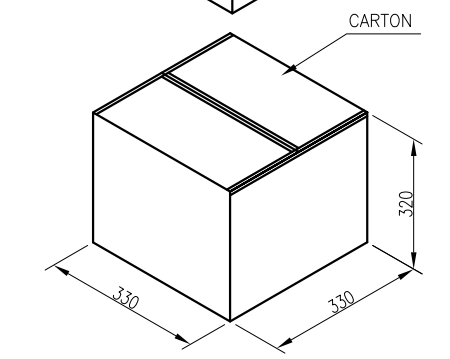
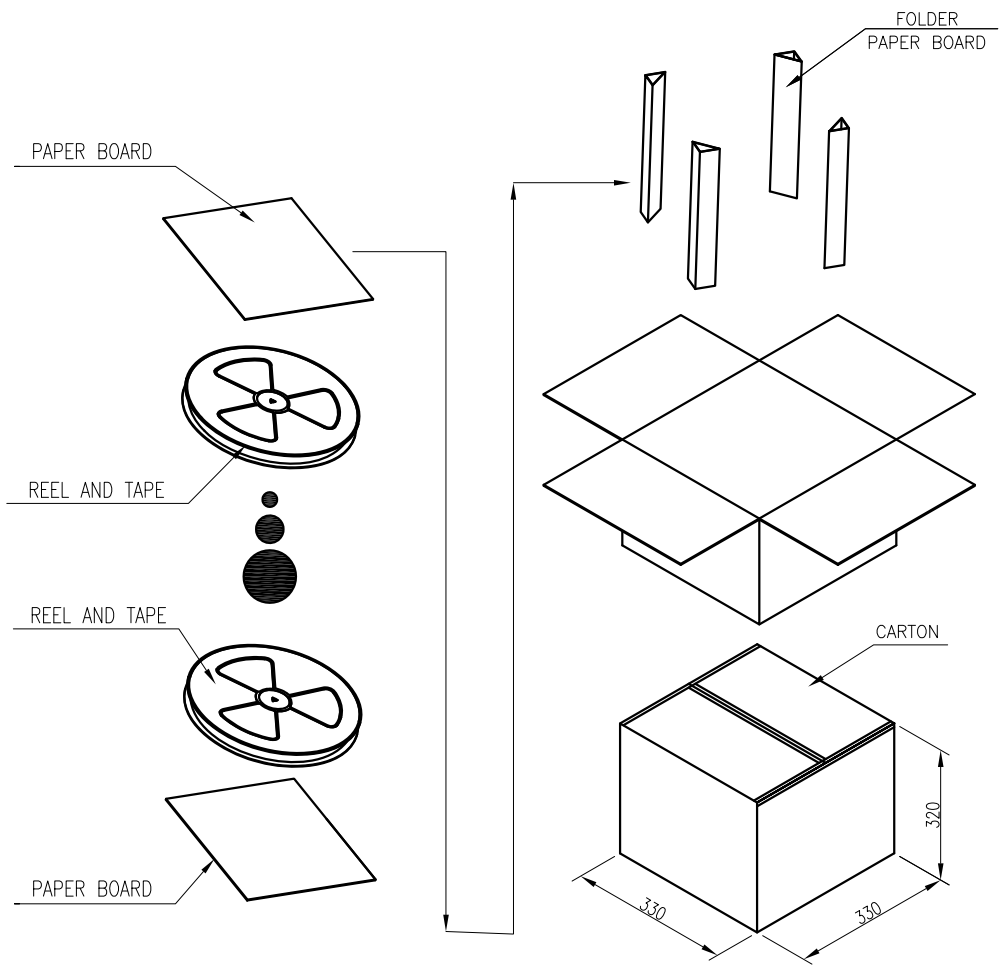
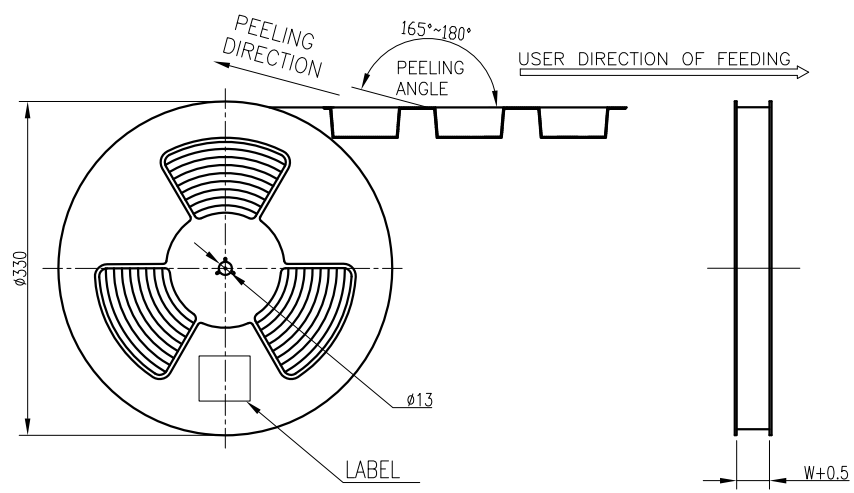

CONN. PART NO.	CONN. QTY./REEL	REEL QTY./CARTON	CONN. QTY./CARTON
TCR16-22121602-XX	1500	10	15000 PCS

UNLESS OTHERWISE SPECIFIED TOLERANCES

DECIMALS:	ANGLES:	泰立电子有限公司 TACLEX ELECTRONICS CO., LTD		
X : ±0.5	X : ±2°	TITLE	Type.C 16PIN L=6.5 CONN. RECPTACLE	
X.X : ±0.30	X.X : ±1°	DWN	chenjun	PART NO. TCR16-22121602-XX
X.XX : ±0.20		CHKD	chenjun	SCALE:1:1 UNIT: mm
X.XXX : ±0.10		APVD	Kevin.d	SIZE: A4 SHEET:10F1 REV: A
		DRAW NO. C-DWG-TCR16-02		CUSTOMER COPY